

050000-000129

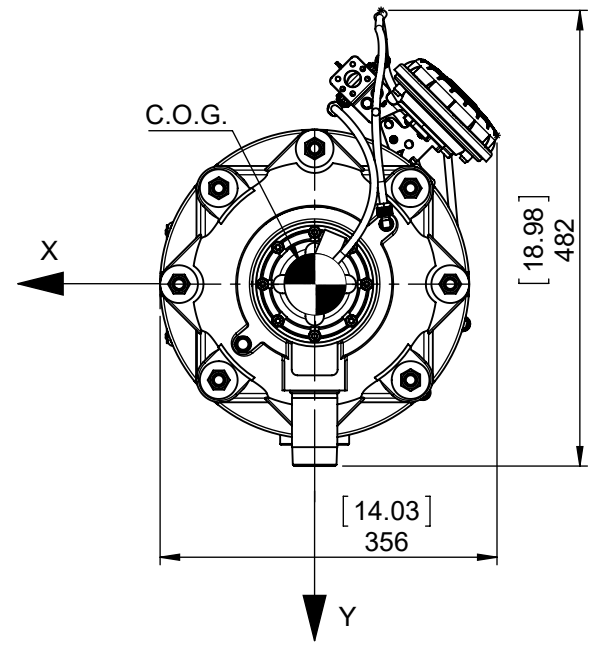
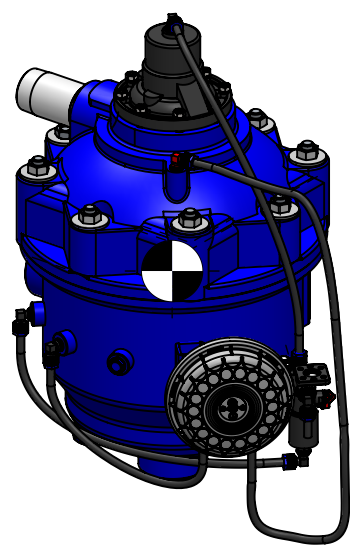

WEIGHT		
POUNDS	KG	
59	27	
CENTER OF GRAVITY		
AXIS	INCH	MM
X	-0.0	-0.8
Y	-0.0	-0.3
Z	9.0	229

LINEAR GENERAL TOLERANCES (mm)						
DIMENSIONS	0.5-3	>3-50	>50-120	>120-400	>400-1000	>1000
TOLERANCE	±0.5	±1	±1.5	±2.5	±4	±6

UNLESS OTHERWISE SPECIFIED: DIMENSIONS ARE IN MILLIMETERS		PART NAME/TITLE: M102C ADI-P Control		Confidential property information. Amiad Water Systems Ltd.	
DRAWN	NAME	DATE	SUBJECT/PROJECT: 050000-000129 for 10 mic npt 2" M100-750 Threaded		
APPROVED			MATERIAL: VARIOUS		CAT. NO.:
<a href="http://www.irrigationglobal.com">www.irrigationglobal.com</a> Filtomat M100 Filters Online Orders and tech support			WEIGHT: 27 KG		DRW. NO.:
					KHG1.H020S.003
					SCALE: 1:8
					SIZE: A4
					SHEET 1 OF 1