

DG-10 PN 10

D-040 PN 16



Combination Air Valve

Description

The D-040 series Combination Air Valve has the features of both an air release valve and an air & vacuum valve.

The air release component is designed to automatically release small pockets of air to the atmosphere as they accumulate at peaks or along a pipeline or piping system when it is full and operating under pressure.

The air & vacuum component is designed to automatically discharge or admit large volumes of air during the filling or draining of a pipeline or piping system. This valve will open to relieve negative pressures whenever water column separation occurs.

Applications

- Pump stations: after the pump and after the check valve.
- On main lines and heads of systems.
- At the end of lines and at the end of a sub main
- On strainers and filters.

Operation

The air & vacuum component, with the large orifice, discharges air at high flow rates during the filling of the system and admits air into the system at high flow rates during its drainage and at water column separation.

High velocity air will not blow the float shut. Water will lift the float, which seals the valve.

At any time during system operation, should internal pressure of the system fall below atmospheric pressure, air will enter the system.

The smooth discharge of air reduces pressure surges and other destructive phenomena.

The intake of air in response to negative pressure protects the system from destructive vacuum conditions and prevents damage caused by water column separation. Air entry is essential to efficiently drain the system.

The air release component releases entrapped air in pressurized systems.

Without air valves, pockets of accumulated air may cause the following hydraulic disturbances:

- Restriction of effective flow due to a throttling effect as would a partially closed valve. In extreme cases this will cause complete flow stoppage.
- Obstruction of efficient hydraulic transmission due to air flow disturbances.
- Accelerate cavitation damages.
- Pressure transients and surges.

- Corrosion in pipes, fittings and accessories.
- Danger of a high-energy burst of compressed air.
- Inaccuracies in flow metering.

As the system starts to fill, the valve functions according to the following stages:

1. Entrapped air in the pipeline is discharged by the valve.
2. Liquid enters the valve, lifting the float which pushes the sealing mechanism to its sealing position.
3. Entrapped air, which accumulates at peaks and along the system, rises to the top of the valve, which in turn displaces the liquid in the valve's body.
4. The float descends, unsealing the rolling seal. The air release orifice opens and the accumulated air is released.
5. Liquid enters into the valve and the float rises, pushing the rolling seal back to its sealing position.

When internal pressure falls below atmospheric pressure (negative pressure):

1. The float will immediately drop down, opening the air & vacuum and air release orifices.
2. Air will enter the system.

Main Features

- Working pressure range: **DG-10** 0.1-10 bar. **D-040** 0.2-16 bar
- Testing pressure: **DG-10** 16 bar. **D-040** 25 bar.
- Maximum working temperature: 60° C.
- Maximum intermittent temperature: 90° C.
- Reliable operation reduces water hammer incidents.
- Dynamic design allows for high velocity air discharge while preventing premature closure.
- Lightweight, small dimensions, simple and reliable structure.
- The discharge outlet enables removal of excess fluids.
- The large size of the automatic air release orifice relative to the air valve body:
 - Discharges air at high flow rates.
 - Lessens the danger of its obstruction by debris.
 - Enables the usage of the patented rolling seal mechanism, making it less sensitive to pressure differential than a direct float seal.
- The body is made of high-strength composite materials and all operating parts are made of specially selected, corrosion-resistant materials.
- Due to its light weight, the valve may be installed on plastic piping systems, as well as other lightweight piping systems.

Valve Selection

The air valve is available with:

- Wide size range: 1/2", 3/4", 1", 2" threaded male connections, NPT or BSPT.
- Ball valve tap, BSPT or NPT male connection.
- The valve is available with a one-way check valve.

Upon ordering, please specify: model, size, working pressure, threads standard and type of liquid.

AIR AND VACUUM FLOW RATE

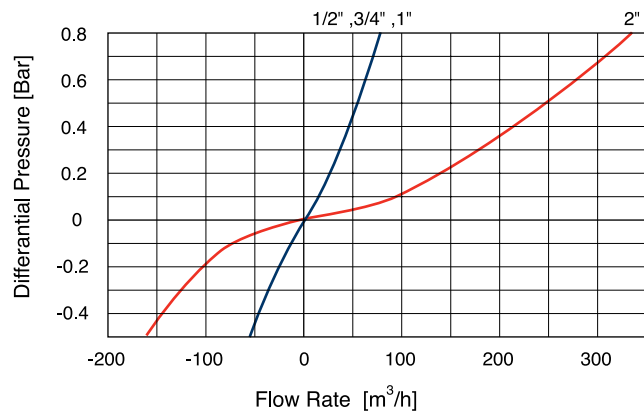

AUTOMATIC AIR RELEASE FLOW RATE

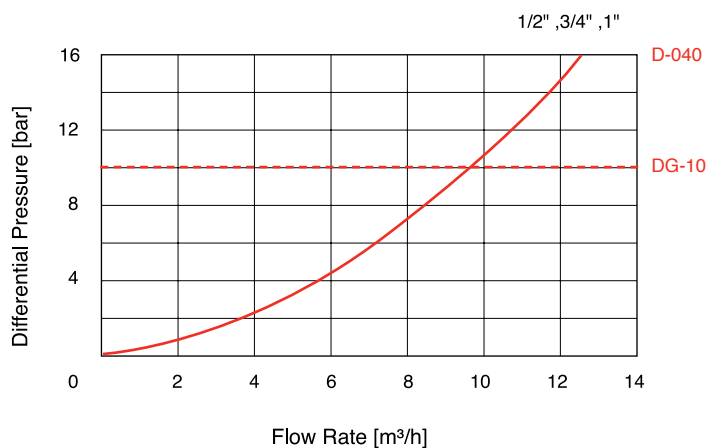

AUTOMATIC AIR RELEASE FLOW RATE

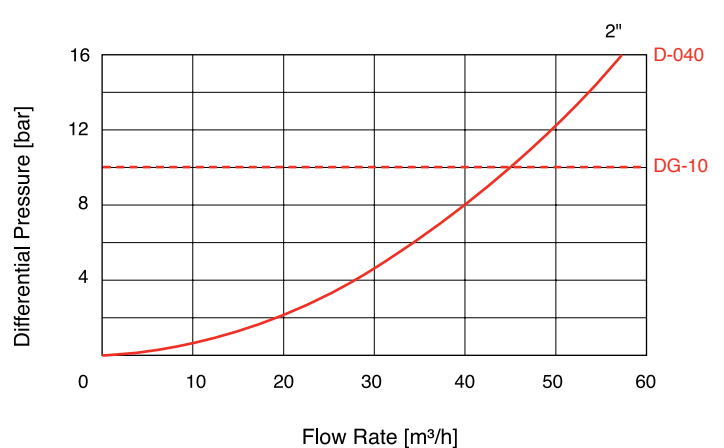



DG-10 2"



DG-10 1"



D-040 2"



D-040 1"

DIMENSIONS AND WEIGHTS

| Nominal Size | Dimensions mm | | Connection C | Weight Kg. | Orifice Area mm ² | |
|--------------|---------------|-----|-------------------|------------|------------------------------|-------|
| | A | B | | | Auto. | A / V |
| 1/2" 3/4" 1" | 100 | 143 | 3/8" BSP Female | 0.33 | 7.8 | 100 |
| 2" | 183 | 215 | 1 1/2" BSP Female | 1.10 | 12 | 804 |

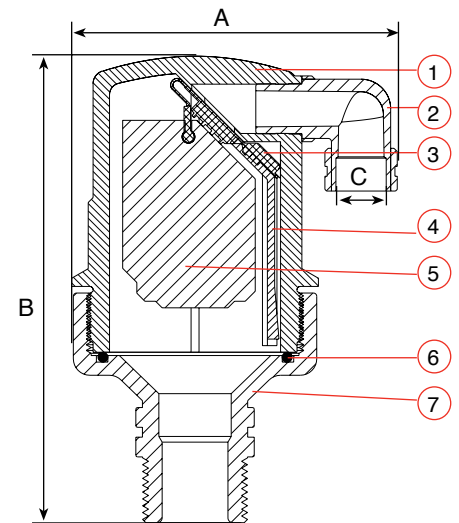

PARTS LIST AND SPECIFICATION

| No. | Part | Material |
|-----------------|---------------------------|---|
| 1. | Body | Reinforced Nylon |
| 2. | Discharge Outlet | Polypropylene |
| 3. | 1/2" 3/4" 1" Rolling Seal | E.P.D.M. |
| | 2" Rolling Seal Assembly: | |
| 3a. | Screws | Stainless Steel SAE 304 |
| 3b. | Plug Cover | Reinforced Nylon |
| 3c. | Rolling Seal | E.P.D.M. |
| 3d. | Plug | Reinforced Nylon |
| 4. | Clamping Stem | Reinforced Nylon |
| 5. | Float | Foamed Polypropylene |
| 6. | O-Ring | BUNA-N |
| 7. | Base | Reinforced Nylon / Brass ASTM B124 / St.St. SAE 316 |
| Optional | Ball valve | Brass ASTM-B-124, Nickel plated. |

