

Arkal 3” Leader Twin Filter with a detachable spine

Catalog No. 1320 3_ _ _ Threaded
1321 3_ _ _ Victaulic
1321 5_ _ _ Arkal Flange

Features

- 3” - VIC, AR-Flange, Threaded Inlet / Outlet options
- Non-corrosive
- Detachable spine
- Pressure differential disc compression
- Robust design
- High volume filter with increased flow capacity
- Easy to open and close filter cover
- Pressure testing ports are at the filters inlet and outlet
- Available in various filtration grades
- Drain valve

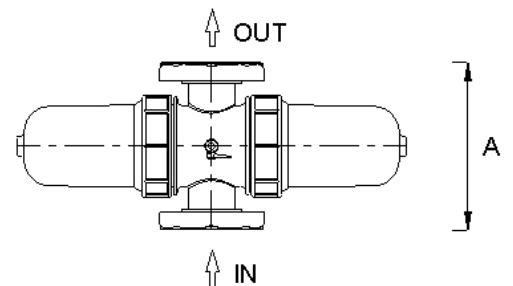
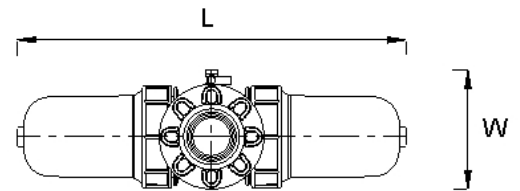

Technical Data

Inlet/Outlet diameter	3” Arkal Flange	3” Arkal Flange
Max. Pressure	10 bar	145 psi
Max. Flow rate 400-100 micron	45 m ³ /h (12.5 l/sec)	198 gpm
55 micron	27 m ³ /h (7.4 l/sec)	119 gpm
20 micron	13 m ³ /h (3.6 l/sec)	57 gpm
Filtration area	1900 cm ²	294.5 in ²
Filtration volume	2450 cm ³	174 in ³
Filter width W	226 mm	8 7/8”
Filter length L	742 mm	29 7/32”
Distance between connections A	320 mm	12 19/32”
Weight (Victaulic, Threaded)	6.3 Kg	14 lbs
Weight (Flanged)	10 Kg	22 lbs
Maximum temperature	60° C	140° F
pH	2-13	2-13

Filtration Grades

- Blue (400 micron / 40 mesh)
- Yellow (200 micron / 80 mesh)
- Red (130 micron / 120 mesh)
- Black (100 micron / 140 mesh)
- Green (55 micron)
- Grey (20 micron)

Head Loss Chart

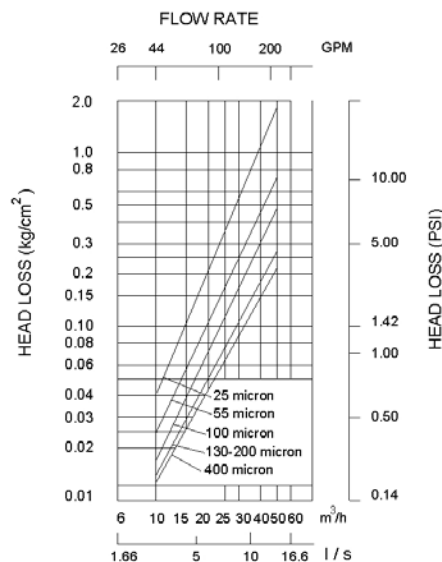

Installation Recommendations

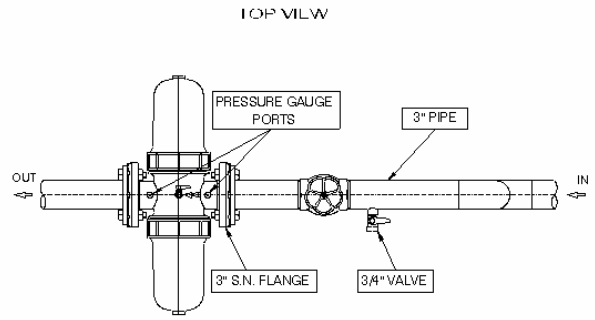
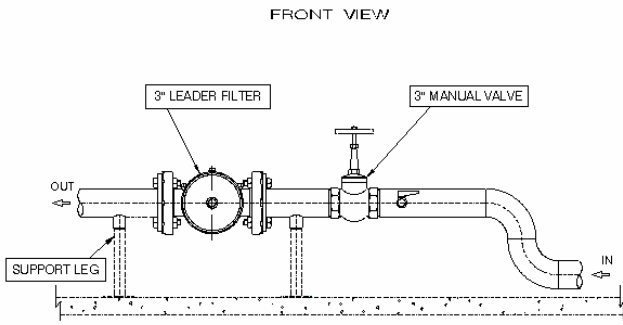

Dismantling

1. Make sure that the water pressure is turned off!
2. Drain the filter through the drainage valve.
3. Open filter cover, and remove from filter body.
* Please Note: Tools are not required! (Manual use only).
4. The detachable spine is loose in the cover.
5. Flush the filter element.
6. If the filter discs require acid treatment you may dip the complete filter element in acid.

Assembly (in reverse order)

1. Position the filter element into the filter cover.
2. To verify that the element is in position, turn the cover while gently pressing on top until it is in place.
3. Tighten the filter cover on the body and close.
* Please Note: Tools are not required! (Manual use only).

Attention!

To verify proper closing, (without tools) please follow the instructions below.

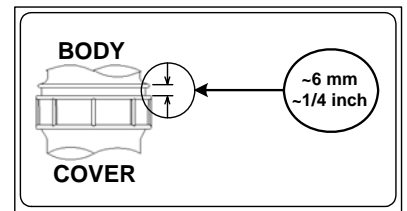

Part List

No.	Cat. No.	Description	Materials
1	2501 0230	Cover	PP
2	2502 0230	Spine	PP
3	2021 1_ _ _	Disc sets	PP
	2031 1_ _ _	Double disc sets	PP
4	2507 0208	Stop ring element	PP
5	5003 1457	O-ring 144.3x5.7	EPDM
6	2232 1011	Victaulic ends body complex	
6.1	5054 0212	1/2"x1/4" Tap	BRASS
6.2	5006 0004	Gauge port seal	EPDM
6.3	2511 0103	Gauge port nut	RPP
7	2125 1_ _ _	Single filter element	PP
	2135 1_ _ _	Double filter element	PP
8	2232 5011	Victaulic body complex with flange	
9	2510 0325	3" Arkal flange (ASA, DIN, BSTD)	RPA
10	2507 0308	Flange cone	POM
11	5005 2013	3" Gasket	EPDM
12	2253 0325	3" Arkal flange complete	
13	2530 0117	Cover wrench	RPA

Materials

PP - POLYPROPYLENE

RPP - REINFORCED POLYPROPYLENE

RPA - REINFORCED POLYAMIDE

POM - POLYOXYMETHYLENE

